

# PS2000W Series

Focusing on high-end industrial laser applications



## Typical Applications:

PS2000W scan welding system comprises collimator, galvanometer scanner, F-theta lenses, interface control cards and air knife to provide an integrated solution with optimal performance for various applications. It is also ideally suited to laser welding, laser cutting, laser cleaning, etc.

The system is characterized by its extraordinary tightness and safety design, and can be easily integrated into machines and product lines. The system is cost-efficient while exhibiting great dynamic performance, high positioning accuracy, low temperature drift and excellent long-term stability, thus making it suitable for various high-end demanding applications.

Specifications are subject to change without notice.  
Copyright © Precision Scan Inc. All Rights Reserved.

[www.precisionscan.ca](http://www.precisionscan.ca)

# PS2000W Series



Focusing on high-end industrial laser applications

**Mechanical Drawings** (Dimensions in mm)

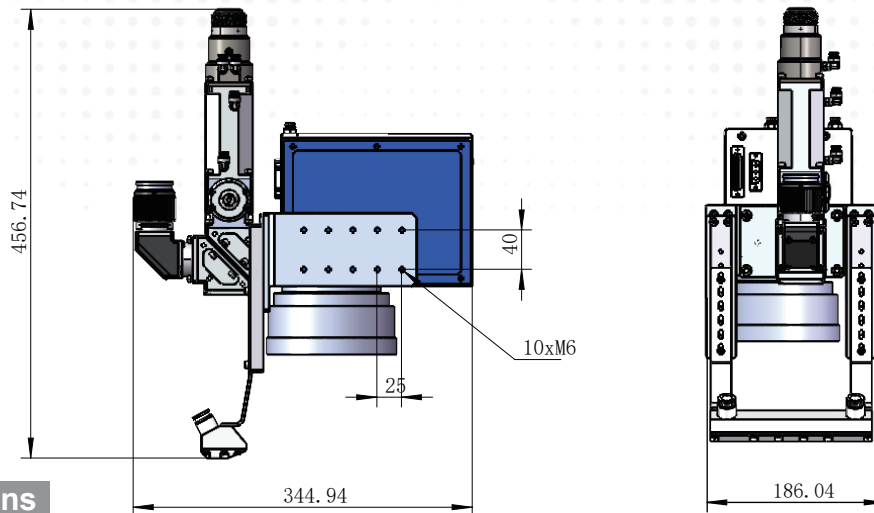

## Specifications

Specifications	PS2000W Series
Maximum allowed average laser power <sup>(1)</sup>	2000 W
Cooling	Water
Aperture	20 mm
Typical scan angle <sup>(2)</sup>	± 10 °
Tracking error	≤ 0.28 ms
Step response time (1% of full scale )	≤ 0.6 ms
<b>Speed</b>	
Positioning / Jump <sup>(3)</sup>	< 20 m/s
Line scan <sup>(3)</sup>	< 20 m/s
Vector scan <sup>(4)</sup>	< 3.5 m/s
<b>Precision</b>	
Linearity	99.9 %
Repeatability	2 μrad
<b>Temperature drift (with laser power &lt; 500W )</b>	
Offset	20 μrad/°C
Gain	20 μrad/°C
<b>Long-term drift(after 30 mins warm up)<sup>(5)</sup></b>	
Over 8 hours long-term offset drift	40 μrad
Over 8 hours long-term gain drift	80 μrad
Operating Temperature Range	25 °C ± 10 °C
Signal interface	Analog: ± 10 V or ± 5 V Digital: XY <sub>2</sub> - 100, PRS422 protocol
Input power requirement (DC)	± 15 V @ 10 A Max RMS

**Note:**

- (1) For laser wavelength 1030-1090 nm.
- (2) All angles are in mechanical degrees.
- (3) With F-Theta objective f = 348 mm. Speed value varies correspondingly with different focal lengths.
- (4) Repeatability and temperature drift are measured within this speed.
- (5) Long-term temperature drift is given under an ambient temperature environment of 25°C. and a working load under 500W. Temperature drift testing with high laser power is strictly prohibited. High laser power could induce thermal deformations in both the optical and mechanical systems, making it impossible to differentiate whether the drift is originating from galvanometer scanner itself or due to deformations in the optical and mechanical systems.