

PSH14AW Scan Head

Focusing on high-end industrial laser applications

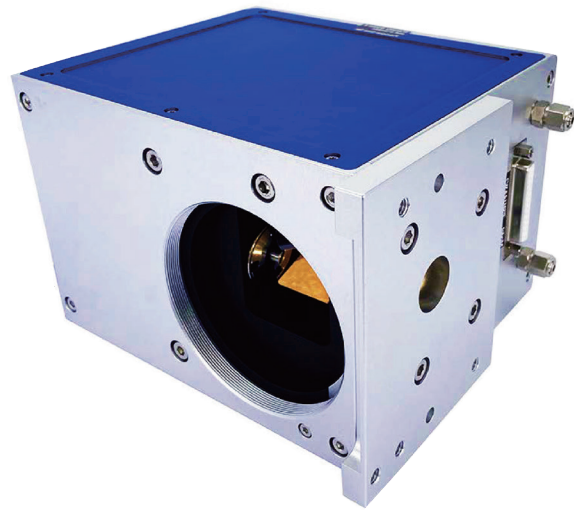

Typical Applications:

PSH14AW is designed to fulfill the most stringent demands and is utilized widely across diverse laser processing applications, such as additive manufacturing(3D printing), materials processing in the semiconductor industry, multi-head manufacturing, micro-structuring, drilling, high-speed laser cleaning, cladding, processing-on-the-fly, scribing, cutting, applications in solar industry, etc.

The product is distinguished by its superior high precision, highest speed, minimal temperature drift and extraordinary long-term stability, while maintaining maximum flexibility in terms of usage.

Specifications are subject to change without notice.
Copyright © Precision Scan Inc. All Rights Reserved.

www.precisionscan.ca

PSH14AW Scan Head

Focusing on high-end industrial laser applications



Mechanical Drawings

(Dimensions in mm)

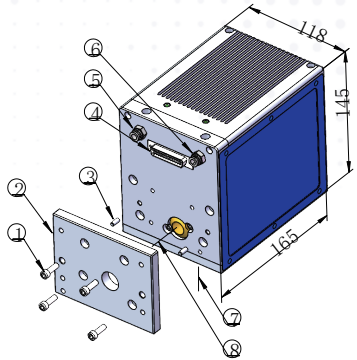

PSH14AW Scan Head

Legend :

1. Mounting screws(M5*16)
2. Installation flange
3. Alignment pins ($\phi 4$)
4. Electrical connectors (XY2-100, Power in)
5. Water in
6. Water out
7. Beam out
8. Beam in

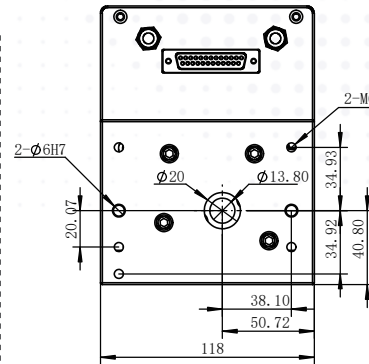

Beam In & Mounting Bracket

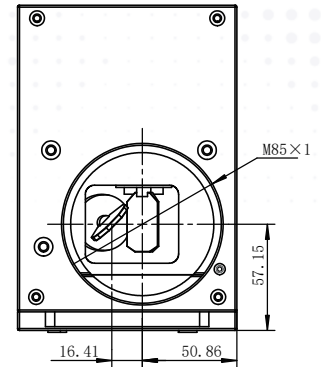

Beam Exit Side

Specifications

Specifications	PSH14AW
Maximum allowed average laser power ⁽¹⁾	500 W
Cooling	Water
Aperture	14 mm
Typical scan angle ⁽²⁾	$\pm 10^\circ$
Tracking error	≤ 0.16 ms
Step response time (1% of full scale)	≤ 0.36 ms
Speed	
Positioning / Jump ⁽³⁾	< 15 m/s
Line scan ⁽³⁾	< 15 m/s
Vector scan ⁽⁴⁾	< 3 m/s
Good writing quality ^{(3) (5)}	750 cps
Precision	
Linearity	99.9 %
Repeatability	2 μ rad
Temperture drift(with laser power < 500W)	
Offset	15 μ rad/°C
Gain	15 μ rad/°C
Long-term drift (after 30 mins warm up) ⁽⁶⁾	
Over 8 hours long-term offset drift	25 μ rad
Over 8 hours long-term gain drift	50 μ rad
Operating Temperature Range	25 °C \pm 10 °C
Signal interface	Analog: ± 10 V or ± 5 V Digital: XY ₂ - 100, PRS422 protocol
Input power requirement (DC)	± 15 V @ 5 A Max RMS

Note:

- (1) For laser wavelength 1030-1090 nm.
- (2) All angles are in mechanical degrees.
- (3) With F-Theta objective f = 163 mm. Speed value varies correspondingly with different focal lengths.
- (4) Reapeatability and temperature drift are measured within this speed.
- (5) Single-stroke font with 1 mm height.
- (6) Long-term temperature drift is given under an ambient temperature environment of 25°C. and a working load under 500W. Temperature drift testing with high laser power is strictly prohibited. High laser power could induce thermal deformations in both the optical and mechanical systems, making it impossible to differentiate whether the drift is originating from galvanometer scanner itself or due to deformations in the optical and mechanical systems.